

LIMIT SWITCHES



An ISO 9001:2015 Certified Company... OEM Supplier to MNCs Since 1990

Corporate office and works: RMG Electromech (P) Ltd, No.41&42, 1st Cross,SMR Layout
 Kereguddadahalli, Chikkabanavara P.O, Bangalore-90,
 Tel: +91-80-23253325/26/27

Mob: +91-9341216734 web: www.rmgpl.com email: info@rmgpl.com, jose@rmgpl.com

DESCRIPTION

Limit switch Assemblies are used in a variety of applications and environments on account of their ruggedness, ease of installation and long term reliability. They can determine the positioning and end of travel etc. of an Actuator/Control valve/Power cylinder. They were first used to define the limit of travel of an object; hence the name "Limit Switch Assembly". The back lever extended from the shaft of the Limit switch Assembly has to be coupled with the moving stem of the valve/actuator to monitor the Position. The position of the running system shall be determined by the CAM setting/sensing plate. The end limits are pre-set at user's place depending on the system/plant requirement. The contacts of the Limit switches are terminated to multi terminal blocks or suitable customized connectors.

SALIENT FEATURES

- Micro switches used are capable of handling high/Low current outputs.
- Highly rugged, reliable, user friendly and easy to install.
- Wide operating temperature range.
- Any type of cable entry could be provided.
- Minimal effect of ambient temperature variance on performance.
- Compact in size as compared to other Limit switch assemblies available in the market.
- High Isolation and Dielectric strength.
- Die-cast AL enclosure capable of enduring high hydrostatic pressure.
- Enclosure protection as per IS/IEC 60529 Standard for IP67.
- Flame/Explosion proof models are available.
- Microcontroller based Limit switches, "SMART Limit Switches" for special applications.
- One year replacement warranty on manufacturing defects.

APPLICATION

- All application, where the end limit of a running system needs to be monitored.
- Process automation environment.



Corporate office and works: RMG Electromech (P) Ltd, No.41&42, 1st Cross,SMR Layout Kereguddadahalli, Chikkabanavara P.O, Bangalore-90, Tel: +91-80-23253325/26/27 Mob: +91-9341216734 web: www.rmgpl.com email:info@rmgpl.com, jose@rmgpl.com

Redefining Mechatronics Globally



RMG-LSA-4S

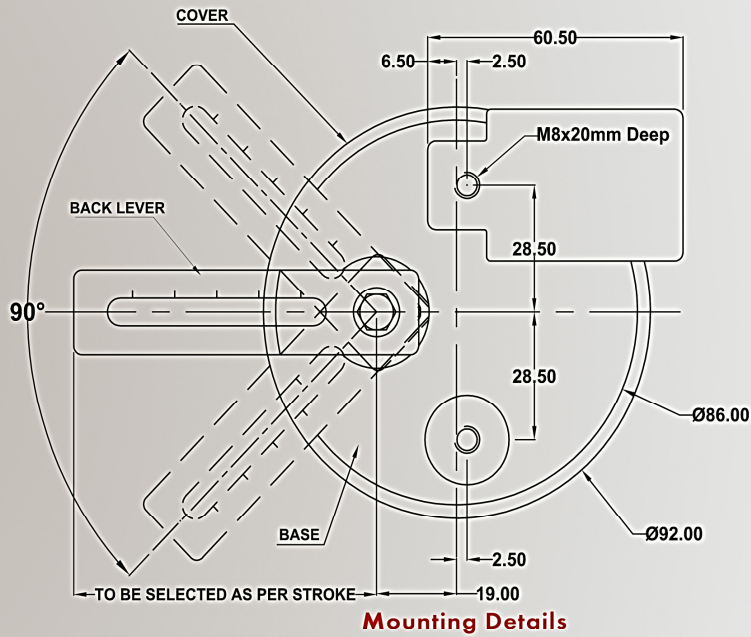

Specification

SL.NO	CHARACTERISTICS	SPECIFIED VALUE
1	No. of Micro Switches Used	04 Nos.
2	Micro Switch	SPDT (1NO+1NC), high temperature grade, Honeywell make.
3	No. of position can be set.	04Nos.
4	Switch Rating	0.5 A at 125 Vdc, 0.25A at 250 Vdc, 10A at 125 Vac/250Vac.
5	Isolation at 500 VDC	>500MΩ between chassis and the shorted wires of Micro Switches.
6	Di- Electric Strength	1.5 k V RMS for 1 minute between chassis and shorted wires of Micro Switch.
7	Cable Entry.	1/2" NPT (std), Other options are available on request.
8	Built In Protection	Enclosure withstands Hydrostatic Pressure up to 10kg/cms ² for 1 Minute.
9	Enclosure & Finish	Aluminium LM 6 Gravity Die Cast, Enamel Painted and Oven Baked.
10	Enclosure Protection	Complies with Ingress Protection Requirements of IP67 as per (Safety & Sealing) IS/ IEC 60529 standard
11	Size	Ø92mmx125mm (H).
12	Weight	≤ 1.2kg.

Note 1 : Due to continuous product improvement initiatives, specification is subject to change.

Note 2: Images provided are for indicative purpose only. Accessories shown are not part of standard supply.

In addition, we design and manufacture LIMIT SWITCH ASSEMBLY as per customer requirements/specifications

Corporate office and works: RMG Electromech (P) Ltd, No.41&42, 1st Cross,SMR Layout
Kereguddadahalli, Chikkabanavara P.O, Bangalore-90, Tel: +91-80-23253325/26/27
Mob: +91-9341216734 web: www.rmgpl.com email: info@rmgpl.com,jose@rmgpl.com

Redefining Mechatronics Globally

