

**POSITION TRANSMITTER
 2 WIRE – NON CONTACT INDUCTIVE**

MODEL: RMG-UPT-EX-IS-0501



DESCRIPTION

RMG-UPT-EX-IS-0501 is a Loop powered 2 wire Position Feedback Transmitter, widely used to transmit the position of a Control Valve / Power Cylinder / Electric Actuator in a variety of process control applications. This contactless Inductive LVDT based Position Transmitter is a 24V DC operated, Angular Position Transmitter designed for both rotary as well as linear movements when coupled with suitable Back Lever and associated hardware. The Position Transmitter processes the input angular movements and gives out 4.00 to 20.00mA signal. **This equipment is Ingress Protection and Intrinsic Safety certified and qualified for use in hazardous environments as per the relevant IS/IEC Standards.**

SALIENT FEATURES

- Intrinsically Safe certified.
- Non-contact, Inductive type.
- Accepts a wide supply voltage range.
- User friendly for easy installation and calibration.
- Wide operating temperature range.
- Minimal effect of ambient temperature variance on accuracy.
- Encapsulated electronics – to protect from moisture, vibration and tampering of the circuitry.
- Has two additional trim pots for 'MID LOW and MID HIGH' positions.
- Compact in size as compared to other position transmitters available in the market.
- High accuracy with minimal Linearity and Hysteresis errors.
- High Isolation and Dielectric strength.
- Suitable for both Rotary and Linear motion.
- Die-cast Aluminium enclosure capable of withstanding high hydrostatic pressure.

APPLICATION

- Position control, monitoring and feedback.
- Custom applications.



Open view with accessories



SPECIFICATIONS

Sl. No.	Characteristics	Specified Value
1	Input – Rotary	0-120° 0-15°/ 0-90°
2	Output	4.00 to 20.00mA
3	Input Supply Voltage Range	10V DC to 28V DC
4	Influence of Input Supply Voltage	≤0.5% of span
5	Type of Transmitter	Two Wire, Loop Powered
6	Type of Sensor	LVDT, non-contact, Inductive.
7	Load Impedance	700 Ω at 24V DC.
8	Operating Temperature Range	-20°C to +80°C.
9	Effect of Temperature	≤0.3% / 10°C.
10	Linearity Error	≤ 0.5% of span
11	Hysteresis Error	≤ 0.5% of span
12	Zero adjustment	±5% of SPAN
13	Span adjustment	±15% of SPAN
14	Type tests qualified for Enclosure (Safety and Sealing) and Intrinsic Safety Protection.	Weatherproof, Flame Proof, and Intrinsically safe requirements of IS/IEC 60079-0:2007, IS/IEC 60079-11:2006 and IS/IEC 60529-2001 Test certificate no. CIMFR/TC/P/584 dt.26.05.2017 from CIMFR, Dhanbad.
15	Built in Protection	a) Isolation at 500V DC ≥500 MΩ. b) Dielectric strength ≥1.5KV rms for 1 Minute. c) Reverse Polarity protected. d) Enclosure withstands hydrostatic pressure up to 20Kg/cm ² for 1 Minute. e) Sensor and Current Converter are epoxy moulded for protection from moisture, vibration and tampering of circuitry.
16	Cable entry	Cable Gland ½” NPT standard.
17	Size	Ø103mm, Height – 122mm.
18	Weight	≤1.5 Kg
19	Enclosure & finish	Aluminium (LM6) gravity die-cast; MRF PU based air dry paint.
20	Accessories	Back Lever with mounting fasteners.

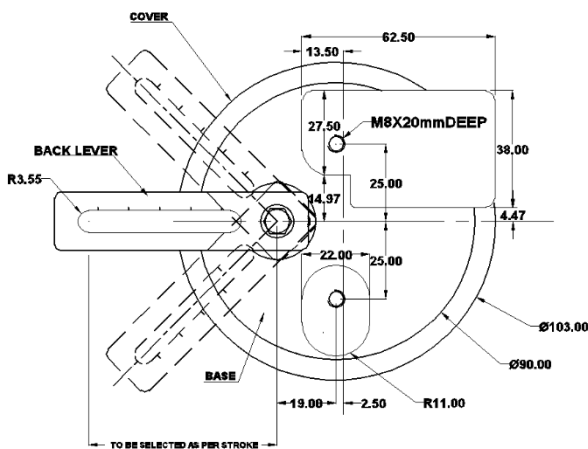

Mounting details with dimensions

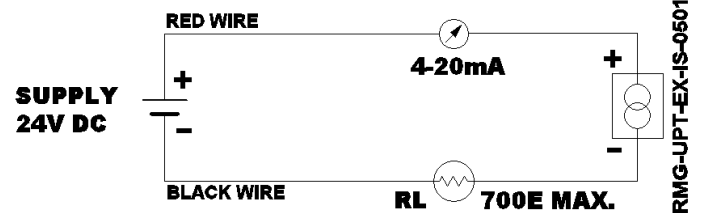

Connection diagram

- Due to continuous product improvement initiatives, specification is subject to change.
- The images provided are for indicative purposes only. The accessories shown are part of standard supply.
- In addition, we design and manufacture Position Feedback Transmitters as per customer requirements / specifications