

**POSITION TRANSMITTER**  
**2 WIRE – HALL EFFECT NON CONTACT**

**MODEL: RMG-HPT2W-EX-2018**



**SALIENT FEATURES**

- Non-contact, Hall Effect Sensor.
- Embedded design using Micro Controller.
- Accepts a wide supply voltage range.
- User friendly for easy installation and calibration.
- Wide operating temperature range.
- Minimal effect of ambient temperature variance on accuracy.
- Compact in size as compared to other position transmitters available in the market.
- High accuracy with minimal Linearity and Hysteresis errors.
- High Isolation and Dielectric strength.
- Suitable for both Rotary and Linear motion.
- Die-cast Aluminium enclosure capable of withstanding high hydrostatic pressure.

**APPLICATION**

- Position control, monitoring and feedback.
- Custom applications.

**DESCRIPTION**

**RMG-HPT2W-EX-2018** is a Loop powered 2 wire Position Feedback Transmitter, widely used to transmit the position of a Control Valve / Power Cylinder / Electric Actuator in a variety of process control applications. This contactless Hall effect sensor-based Position Transmitter is a 24V DC operated, Angular Position Transmitter. Because of the unique design technique incorporating embedded design using micro controller, both rotary as well as linear movements can be measured/monitored with equal ease when coupled with a suitable Back Lever and associated hardware. The Position Transmitter processes the input angular/rotary movements and gives out 4.00 to 20.00mA signal with exceptional accuracy. **This Instrument is certified and qualified for Ingress Protection and for use in Flame Proof/Explosion Proof areas and environments as per the relevant IS/IEC standards.**



**Open view with accessories**



**SPECIFICATIONS**

Sl. No.	Characteristics	Specified Value
1	Input-Rotary	0 - 360° 0 - 180°/0- 270°
2	Output	4.00 to 20.00mA
3	Input Supply Voltage Range	10V DC to 60V DC
4	Influence of Input Supply Voltage	≤0.2% of span
5	Type of Transmitter	Two wire, Loop Powered
6	Type of Sensor	Hall Effect Sensor, non-contact
7	Load Impedance	700 Ω at 24V DC
8	Operating Temperature Range	-20° C to +80°C
9	Effect of Temperature	≤0.1% / 10°C
10	Built-in error correction incorporated using Micro Controller	a) Tan Ø b) Manual Mode
11	ZERO & SPAN Setting [Software Assisted]	Through Pushbutton Switches
12	Forward & Reverse Selection	Through Dip Switches
13	Linearity Error	≤ 0.5% of span.
14	Hysteresis Error	≤ 0.5% of span.
15	Midpoint Linearity Adjustment [Software Assisted]	Maximum of 15 points can be adjusted.
16	Type tests qualified for Enclosure protection (Safety and Sealing)	Weatherproof / Flame Proof requirements of IS/IEC 60079-0:2017, IS/IEC 60079-1:2014, IS/IEC 60079-31:2022 and IS/IEC 60529-2001[Reaffirmed2014]. Test and assessment Report no.IN/CIMFR/TR24/P/1162 dt.20.09.2024 from CIMFR, Dhanbad.
17	Built in Protection	a) Isolation at 500V DC ≥500 MΩ. b) Dielectric strength ≥1.5KV rms for 1 Minute. c) Reverse Polarity protected. d) Enclosure withstands hydrostatic pressure up to 20Kg/cm <sup>2</sup> for 1 Minute.
18	Cable entry	Cable Gland ½” NPT standard.
19	Size	Ø103mm, Height – 122mm.
20	Weight	<1.5 Kg approx.
21	Enclosure & finish	Aluminium (LM6) gravity die-cast; MRF PU based air dry paint.
22	Accessories	Back Lever with mounting fasteners.

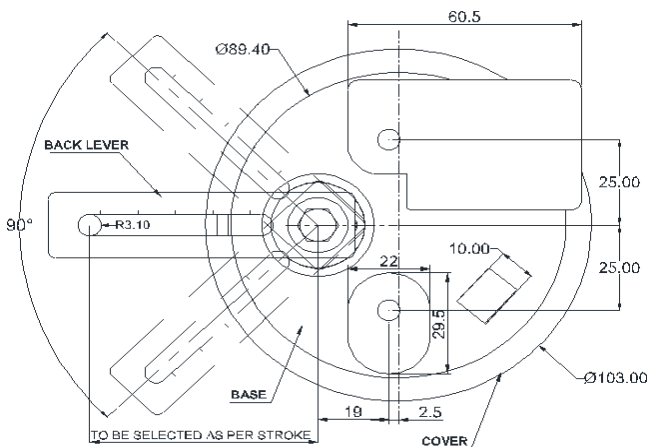

**Mounting details with dimensions**

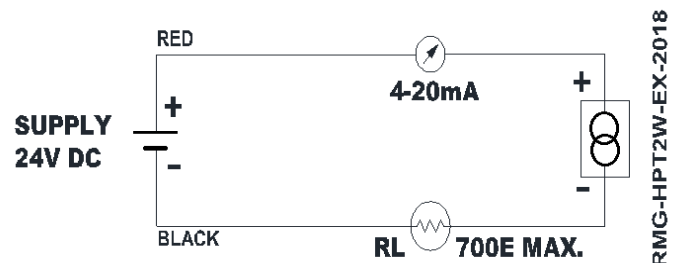

**Connection diagram**

- a) Due to continuous product improvement initiatives, specification is subject to change.
- b) The Images provided are for indicative purposes only. Accessories shown are part of standard supply.
- c) In addition, we design and manufacture Position Feedback Transmitters as per customer requirements / specifications