

**POSITION TRANSMITTER**  
**2 WIRE – HALL EFFECT NON CONTACT**

**MODEL: RMG-HPT2W-EX-IS-2018**



**SALIENT FEATURES**

- Non-contact, Hall effect Sensor based.
- Embedded Design using Micro Controller.
- Accepts a wide supply voltage range.
- User friendly for easy installation and calibration.
- Wide operating temperature range.
- Minimal effect of ambient temperature variance on accuracy.
- Compact in size as compared to other position transmitters available in the market.
- High accuracy with minimal Linearity and Hysteresis errors.
- High Isolation and Dielectric strength.
- Suitable for both Rotary and Linear motion.
- Die-cast Aluminium enclosure capable of withstanding high hydrostatic pressure.

**APPLICATION**

- Position control, monitoring and feedback.
- Custom applications.

**DESCRIPTION**

**RMG-HPT2W-EX-IS-2018** is a Loop Powered 2 wire Position Feedback Transmitter, widely used to transmit the position of a Control Valve / Power Cylinder / Electric Actuator in a variety of process control applications. This contactless Hall effect Sensor based Position Transmitter is a 24V DC operated 2Wire System, using a unique embedded microcontroller-based design suitable for rotary and linear movements as well, when used with appropriate back lever and coupling hardware. The Position Transmitter processes the input rotary signal and converts it into 4.00 to 20.00mA signal. **This equipment is Ingress Protection and Intrinsic Safety certified and qualified for use in hazardous environments as per the relevant IS/IEC Standards.**



**Open view with accessories**



## SPECIFICATIONS

Sl. No.	Characteristics	Specified Value
1	Input - Rotary	0-360° 0-180°/ 0-270°
2	Output	4.00 to 20.00mA
3	Input Supply Voltage Range	10V DC to 28V DC
4	Influence of Input Supply Voltage	≤0.2% of span
5	Type of Transmitter	Two wire, Loop Powered.
6	Type of Sensor	Hall Effect Sensor, non-contact.
7	Load Impedance	700 Ω at 24V DC
8	Operating Temperature Range	-20° C to +80° C
9	Effect of Temperature	≤0.1% / 10°C
10	Built-in error corrections incorporated using Micro Controller	a) Tan Ø b) Manual Mode
11	ZERO & SPAN Setting [Software Assisted]	Through Pushbutton Switches.
12	Forward & Reverse Selection	Through Dip Switches.
13	Linearity Error	≤ 0.5% of span
14	Hysteresis Error	≤ 0.5% of span
15	Midpoint Linearity Adjustment [Software Assisted]	Maximum of 15 points can be adjusted.
16	Type tests qualified for Enclosure (Safety and Sealing) and Intrinsic Safety Protection.	Weatherproof, Flame Proof, and Intrinsically safe requirements of IS/IEC 60079-0:2017, IS/IEC 60079-11:2011 and IS/IEC 60529-2001[Reaffirmed 2014]. Test and assessment Report no.IN/CIMFR/TR24 /P/1099 dt.10.09.2024 from CIMFR, Dhanbad.
17	Built in Protection	a) Isolation at 500V DC ≥500 MΩ b) Dielectric strength ≥1.5KV rms for 1 Minute c) Reverse Polarity protected d) Enclosure withstands hydrostatic pressure up to 20Kg/cm <sup>2</sup> for 1 Minute.
18	Cable entry	Cable Gland ½” NPT standard and Screw type terminals.
19	Size	Ø103mm, Height – 122mm
20	Weight	<1.5 Kg approx.
21	Enclosure & finish	Aluminium (LM6) gravity die-cast; MRF PU based air dry paint
22	Accessories	Back Lever with mounting fasteners.

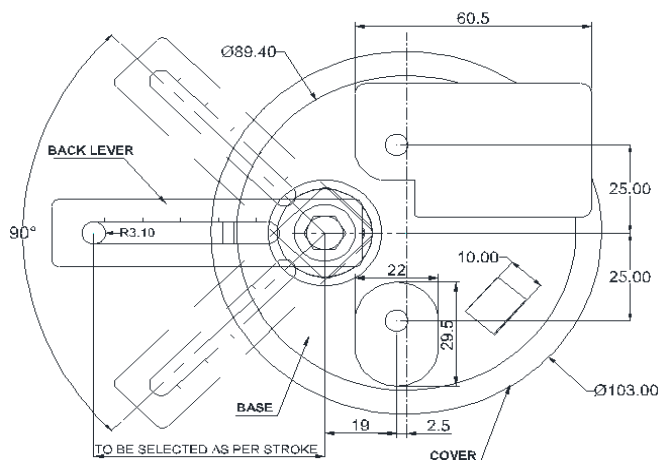

**Mounting details with dimensions**

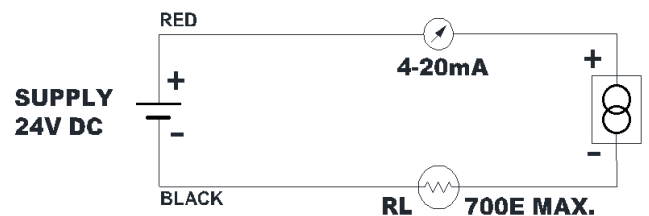

**Connection diagram**

RMG-HPT2W-EX-IS-2018

- Due to continuous product improvement initiatives, specification is subject to change.
- The images provided are for indicative purposes only. Accessories shown are part of standard supply.
- In addition, we design and manufacture Position Feedback Transmitters as per customer requirements / specifications.